

ESTABILIDAD DE LOS VEHÍCULOS CISTERNA

ADR

El ancho total de la superficie de apoyo en la calzada (la distancia que hay entre los puntos de contacto exteriores de los neumáticos derecho e izquierdo de un mismo eje con la calzada) deberá ser, como mínimo, igual al 90% de la altura desde el centro de gravedad, cargado, de los vehículos cisterna. Para los vehículos articulados, el peso sobre los ejes de la unidad portadora del semirremolque no deberá sobrepasar el 60% del peso total nominal, cargado, del conjunto del vehículo articulado.

Además, los vehículos cisterna con cisternas fijas de capacidad superior a 3 m³ destinados al transporte de las mercancías peligrosas en estado líquido o fundido y probados a una presión de menos de 4 bar deberán cumplir las disposiciones técnicas del Reglamento ECE N° 111(1) relativas a la estabilidad lateral, en su redacción modificada, de acuerdo con las fechas de aplicación que allí se especifican. Estas disposiciones se aplicarán a los vehículos cisterna matriculados por primera vez a partir del 1 de julio del 2003.

(1) Reglamento ECE N° 111: Disposiciones relativas a la homologación de los vehículos cisterna de las categorías N y O en lo que se refiere a la estabilidad al giro.

REGLAMENTO ECE N° 111

AGREEMENT

CONCERNING THE ADOPTION OF UNIFORM TECHNICAL PRESCRIPTIONS
FOR WHEELED VEHICLES, EQUIPMENT AND PARTS WHICH CAN BE FITTED AND/OR
BE USED ON WHEELED VEHICLES AND THE CONDITIONS FOR RECIPROCAL RECOGNITION
OF APPROVALS GRANTED ON THE BASIS OF THESE PRESCRIPTIONS */

(Revision 2, including the amendments entered into force on 16 October 1995)

Addendum 110: Regulation No. 111

Date of entry into force: 28 December 2000

**UNIFORM PROVISIONS CONCERNING THE APPROVAL OF TANK VEHICLES
OF CATEGORIES N AND O WITH REGARD TO ROLLOVER STABILITY**



UNITED NATIONS

*/ Former title of the Agreement:

Agreement Concerning the Adoption of Uniform Conditions of Approval and Reciprocal Recognition of Approval for Motor Vehicle Equipment and Parts, done at Geneva on 20 March 1958.

GE.01-20890

Regulation No. 111

UNIFORM PROVISIONS CONCERNING THE APPROVAL OF TANK VEHICLES
OF CATEGORIES N AND O WITH REGARD TO ROLLOVER STABILITY

CONTENTS

REGULATION	<u>Page</u>
1. Scope	
2. Definitions	
3. Application for approval	
4. Approval	
5. Specifications and tests	
6. Modification of the vehicle type and extension of approval	
7. Conformity of production	
8. Penalties for non-conformity of production	
9. Production definitely discontinued	
10. Names and addresses of technical services responsible for conducting approval tests, and of administrative departments	
ANNEXES	
<u>Annex 1</u> - Communication concerning the approval or extension or refusal or withdrawal of approval or production definitely discontinued of a vehicle type with regard to static/steady-state rollover stability pursuant to Regulation No. 111	
<u>Annex 2</u> - Arrangements of the approval mark	
<u>Annex 3</u> - Tilt table test procedure	
<u>Annex 4</u> - Lateral stability calculation	
<u>Appendix</u> - Calculation report	

1. SCOPE

This Regulation applies to the rollover stability of tank vehicles of category N2, N3, O3 and O4 1/ intended for the carriage of dangerous goods as defined in the ADR agreements. 2/

2. DEFINITIONS

For the purposes of this Regulation:

- 2.1. "Approval of a vehicle" means approval of a vehicle type with regard to rollover stability;
- 2.2. "Vehicle type" means a category of vehicle which does not differ in such essential respects as:
- 2.2.1. vehicle category, (see paragraph 1. above) and type (truck, full trailer, semi-trailer, centre-axle trailer) 3/;
- 2.2.2. maximum mass, as defined in paragraph 2.4. below;
- 2.2.3. cross-section profile of the tank (circular, elliptical, maxi-volume);
- 2.2.4. maximum height of the centre of gravity of the laden vehicle;
- 2.2.5. distribution of mass among the axles (including fifth wheel);
- 2.2.6. number and arrangement of the axles (including axle spacing);
- 2.2.7. suspension arrangements in relation to roll characteristics;
- 2.2.8. tyre size and structure (radial ply, diagonal ply or bias belted);
- 2.2.9. track width;
- 2.2.10. wheel base.
- 2.3. "Laden vehicle", except where otherwise stated, means a vehicle so laden as to attain its "maximum mass";

1/ Categories N and O as defined in annex 7 to the Consolidated Resolution on the Construction of Vehicles (R.E.3) (document TRANS/WP.29/78/Rev.1/Amend.2).

2/ European Agreement concerning the International Carriage of Dangerous Goods by Road (ADR).

3/ Category of vehicle as defined in annex 7 to the Consolidated Resolution on the Construction of Vehicles (R.E.3) (document TRANS/WP.29/78/Rev.1/Amend.2).

- 2.4. "Maximum mass" means the technically permissible maximum mass stated by the vehicle manufacturer (this mass may be higher than the "permissible maximum mass" laid down by the national administration);
- 2.5. "The distribution of mass among the axles" means the proportion of the maximum permissible mass borne by each axle, as declared by the vehicle manufacturer;
- 2.6. "Suspension trim height" means the distance between the wheel centre and a fixed point on the chassis as declared by the vehicle manufacturer.
3. APPLICATION FOR APPROVAL
- 3.1. The application for approval of a vehicle type with regard to rollover stability shall be submitted by the vehicle manufacturer 4/ or by his duly accredited representative.
- 3.2. It shall be accompanied by the undermentioned documents in triplicate and the following particulars:
- 3.2.1. a detailed description of the vehicle type with regard to the items specified in paragraph 2.2. above. The numbers and/or symbols identifying the vehicle type shall be specified;
- 3.2.2. photographs and/or diagrams and drawings of the vehicle showing the vehicle type in front, side, and rear elevation;
- 3.2.3. particulars of the vehicle's mass as defined by paragraph 2.4. above.
- 3.3. A vehicle, representative of the vehicle type to be approved, shall be submitted to the Technical Service conducting the approval tests.
4. APPROVAL
- 4.1. If the vehicle type submitted for approval pursuant to this Regulation meets the requirements of paragraph 5 below, approval of that vehicle type shall be granted.
- 4.2. An approval number shall be assigned to each type approved. Its first two digits (currently 00 for the Regulation in its original form) shall indicate the series of amendments incorporating the most recent major technical amendments made to the Regulation at the time of issue of the approval. The same Contracting Party shall not assign the same approval number to another vehicle type.

4/ Manufacturer of the base vehicle or the final assembler of the tank vehicle.

- 4.3. Notice of approval or of extension or of refusal or of approval withdrawn or of production definitely discontinued of a vehicle type pursuant to this Regulation shall be communicated by the Parties to the Agreement applying this Regulation by means of a form conforming to the model in annex 1 to this Regulation together with photographs and/or diagrams and drawings supplied by the applicant for approval, in a format not exceeding A4 (210 x 297 mm) or folded to that format and on an appropriate scale.
- 4.4. There shall be affixed to every vehicle conforming to a vehicle type approved under this Regulation, conspicuously and in a readily accessible place specified on the approval form, an international approval mark consisting of:
- 4.4.1. a circle surrounding the letter "E" followed by the distinguishing number of the country which has granted approval, 5/ and
- 4.4.2. the number of this Regulation, followed by the letter "R", a dash and the approval number, to the right of the circle prescribed in paragraph 4.4.1.
- 4.5. If the vehicle conforms to a vehicle type approved, under one or more other Regulations annexed to the Agreement, in the country which has granted approval under this Regulation, the symbol prescribed in paragraph 4.4.1. need not be repeated; in this case the Regulation and approval numbers and the additional symbols of all the Regulations under which approval has been granted in the country which has granted approval under this Regulation shall be placed in vertical columns to the right of the symbol prescribed in paragraph 4.4.1.
- 4.6. The approval mark shall be clearly legible and be indelible.

5/ 1 for Germany, 2 for France, 3 for Italy, 4 for the Netherlands, 5 for Sweden, 6 for Belgium, 7 for Hungary, 8 for the Czech Republic, 9 for Spain, 10 for Yugoslavia, 11 for the United Kingdom, 12 for Austria, 13 for Luxembourg, 14 for Switzerland, 15 (vacant), 16 for Norway, 17 for Finland, 18 for Denmark, 19 for Romania, 20 for Poland, 21 for Portugal, 22 for the Russian Federation, 23 for Greece, 24 for Ireland, 25 for Croatia, 26 for Slovenia, 27 for Slovakia, 28 for Belarus, 29 for Estonia, 30 (vacant), 31 for Bosnia and Herzegovina, 32 for Latvia, 33 (vacant), 34 for Bulgaria, 35-36 (vacant), 37 for Turkey, 38-39 (vacant), 40 for The former Yugoslav Republic of Macedonia, 41 (vacant), 42 for the European Community (Approvals are granted by its Member States using their respective ECE symbol), 43 for Japan, 44 (vacant), 45 for Australia and 46 for Ukraine. Subsequent numbers shall be assigned to other countries in the chronological order in which they ratify or accede to the Agreement Concerning the Adoption of Uniform Technical Prescriptions for Wheeled Vehicles, Equipment and Parts which can be Fitted and/or be Used on Wheeled Vehicles and the Conditions for Reciprocal Recognition of Approvals Granted on the Basis of these Prescriptions, and the numbers thus assigned shall be communicated by the Secretary-General of the United Nations to the Contracting Parties to the Agreement.

- 4.7. The approval mark shall be placed close to or on the vehicle data plate.
- 4.8. Annex 2 to this Regulation gives examples of approval marks.
5. SPECIFICATIONS AND TESTS
- 5.1. The vehicle shall undergo:
- 5.1.1. a tilt table test in accordance with annex 3 to this Regulation, which simulates a non-vibratory steady-state turn, or
- 5.1.2. as an alternative a calculation method in accordance with annex 4 to this Regulation. If there is any doubt or dispute a tilt table test shall be used.
- 5.2. The result of the tilt table test or the calculation method shall be considered satisfactory if the conditions set out in paragraphs 5.3. and 5.4. below are satisfied.
- 5.3. Stability criteria
- 5.3.1. The criteria, using the corresponding annex (3 or 4) to this Regulation, must fulfil one of the following conditions, subject to paragraph 5.1.2.:
- 5.3.1.1. Tilt table test:
- The static rollover stability of the vehicle shall be such that the point at which overturning occurs would not be passed if a tilt table angle of 23° has been reached for all tests in both tilt directions.
- If the vehicle fails in one of the three tests for a specific direction (right or left), it is allowed to do one consecutive (re)test.
- 5.3.1.2. Calculation method:
- The rollover stability of the vehicle shall be such that the point at which overturning occurs would not be passed if a lateral acceleration of 4 m/s² has been reached.
- 5.4. Particular requirements
- No contact between parts of the vehicle shall occur which are not intended to come into contact during normal use.

6. MODIFICATION OF THE VEHICLE TYPE AND EXTENSION OF APPROVAL

6.1. Every modification which affects the vehicle type as defined in paragraph 2.2 above (for instance the chassis, body, suspension, axle configuration, etc.) shall be notified to the administrative department which approved the vehicle type. The department may then either:

6.1.1. Consider that the modifications made are unlikely to have an appreciable adverse effect and that in any case the vehicle still complies with the requirements, or

6.1.2. Require a further test report from the Technical Service responsible for conducting the tests.

6.2. Confirmation or refusal of approval, specifying the alterations, shall be communicated by the procedure specified in paragraph 4.3. above to the Contracting Parties to the Agreement which apply this Regulation.

6.3. The competent authority issuing an extension of approval shall assign a series number to each communication form drawn up for such an extension and inform thereof the other Contracting Parties to the 1958 Agreement by means of a communication form conforming to the model in annex 2 to this Regulation.

7. CONFORMITY OF PRODUCTION

The conformity of production procedures shall comply with those set out in the Agreement, appendix 2 (E/ECE/324-E/ECE/TRANS/505/Rev.2), with the following requirements:

7.1. A vehicle approved to this Regulation shall be so manufactured as to conform to the type approved by meeting the requirements set forth in paragraph 5 above.

7.2. The authority which has granted type approval may at any time verify the conformity control methods applied in each production facility. The normal frequency of these verifications shall be once every two years.

8. PENALTIES FOR NON-CONFORMITY OF PRODUCTION

8.1. The approval granted in respect of a vehicle type, pursuant to this Regulation, may be withdrawn if the requirement laid down in paragraph 7.1. above is not complied with, or if the vehicle or vehicles selected have failed to pass the checks prescribed in paragraph 7.2. above.

8.2. If a Contracting Party to the Agreement applying this Regulation withdraws an approval it has previously granted, it shall forthwith so notify the other Contracting Parties applying this Regulation by means of a communication form conforming to the model in annex 1 to this Regulation.

9. PRODUCTION DEFINITELY DISCONTINUED

If the holder of the approval completely ceases to manufacture a type of vehicle approved in accordance with this Regulation, he shall so inform the authority which granted the approval. Upon receiving the relevant communication, that authority shall inform thereof the other Parties to the 1958 Agreement applying this Regulation by means of a communication form conforming to the model in annex 1 to this Regulation.

10. NAMES AND ADDRESSES OF TECHNICAL SERVICES RESPONSIBLE FOR CONDUCTING APPROVAL TESTS, AND OF ADMINISTRATIVE DEPARTMENTS

The Contracting Parties to the Agreement applying this Regulation shall communicate to the United Nations secretariat the names and addresses of the technical services responsible for conducting approval tests, and of the administrative departments which grant approval and to which forms certifying approval or extension, or refusal or withdrawal of approval, issued in other countries, are to be sent.

Annex 1

(maximum format: A4 (210 x 297 mm))

COMMUNICATION



issued by: Name of administration:
.....
.....
.....

concerning: 2/ APPROVAL GRANTED
APPROVAL EXTENDED
APPROVAL REFUSED
APPROVAL WITHDRAWN
PRODUCTION DEFINITELY DISCONTINUED

of a vehicle type with regard to static/steady-state rollover stability
pursuant to Regulation No. 111

Approval No. ...

Extension No. ...

1. Trade name or mark of the vehicle:
2. Vehicle category: N2/N3/O3/O4 2/
3. Vehicle type:
- 3.1. chassis; make, model, type:
- 3.2. tank; make, model:
- 3.3. monocoque tank construction: Yes/No 2/
4. Manufacturer's name and address:
5. If applicable, name and address of manufacturer's representative:
6. Mass of vehicle:
 - 6.1. maximum mass of vehicle:
 - 6.2. mass of laden tank:
 - 6.3. distribution of the maximum mass among the axles:

- 6.4. in case of a semi-trailer or centre-axle trailer, the static load on the fifth wheel/front coupling
- 7. Cross-section of the tank: circular/elliptical/maxi-volume 2/
- 8. Centre of gravity height of the laden vehicle:
- 9. Axles:
 - 9.1. number and arrangement of the axles (including axle spacing):
 - 9.2. suspension arrangements in relation to roll characteristics:
 - 9.3. suspension trim height and datum location 3/:
 - 9.4. tyre size and structure: radial ply/diagonal ply/bias belted 2/
 - 9.5. track width of each axle:
- 10. Wheel base:
- 11. Test conditions
 - 11.1. mass of vehicle when tested:

Axle No.	Load (kg)
TOTAL	

- 11.2. load imposed on towing vehicle fifth wheel coupling or centre axle trailer coupling:
- 11.3. filling factor of the test load (% fill of the tank):
- 11.4. test load (water, etc.):
- 12. Vehicle submitted for approval on:
- 13. Technical service responsible for conducting approval tests:
- 14. Date of report issued by that service:
- 15. Number of report issued by that service:
- 16. Tilt table test/calculation method. 2/
- 17. Approval granted/refused/extended/withdrawn. 2/

18. Position of approval mark on the vehicle:
19. Place:
20. Date:
21. Signature:
22. The list of documents deposited with the Administrative Service which has granted approval is annexed to this communication and may be obtained on request.

-
- 1/ Distinguishing number of the country which has granted/extended/refused/withdrawn approval (see approval provisions in the Regulation).
 - 2/ Strike out what does not apply.
 - 3/ In case of height-levelling devices, please specify.

Annex 2

ARRANGEMENTS OF THE APPROVAL MARK

Model A

(See paragraph 4.5. of this Regulation)

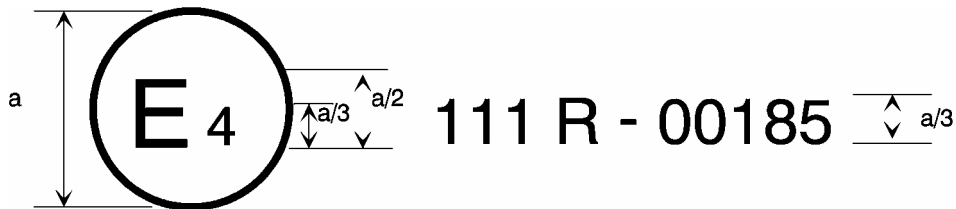

$a \geq 8 \text{ mm min}$

The above approval mark affixed to a vehicle shows that the vehicle type concerned has, with regard to the rollover stability, been approved in the Netherlands (E4) pursuant to Regulation No. 111. The first two digits of the approval number indicate that when the approval was granted Regulation No. 111 was in its original form.

Model B

(See paragraph 4.6. of this Regulation)

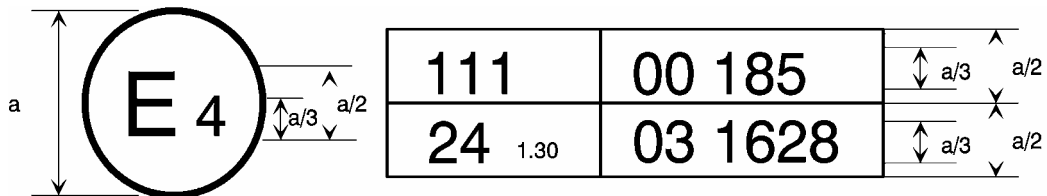

$a \geq 8 \text{ mm min}$

The above approval mark affixed to a vehicle shows that the vehicle type concerned has been approved in the Netherlands (E4) pursuant to Regulations Nos. 111 and 24 */. (In the case of the latter Regulation, the additional symbol which follows the Regulation number indicates that the corrected absorption co-efficient is 1.30 m^{-1}). The first two digits of the approval number indicate that, at the date when the respective approvals were granted, Regulation 111 was in its original form and Regulation No. 24 incorporated the 03 series of amendments.

*/ The latter number is given only as an example.

Annex 3

TILT TABLE TEST PROCEDURE

1. DEFINITIONS

For the purposes of this test:

"Rollover threshold" means the instant when all the wheels on one side of the vehicle have lost contact with the tilt table surface.

2. GENERAL CONDITIONS

2.1. The tilt table

A rigid surface should be used. The tyres may rest against a safety block or step during the test to prevent sideways slipping, provided that the safety block does not influence the test result.

2.2. Wind conditions

If the tilt table test rig is placed outside, the lateral wind velocity shall not exceed 3 m/s and the total wind velocity shall not exceed 5 m/s.

2.3. Tyres

The tyres shall be inflated to pressures as specified by the vehicle manufacturer for the test vehicle at the laden condition. The tolerance for the inflation pressure in a cold state is ∇ 2 per cent.

2.4. Operating components

2.4.1. All operating components likely to influence the results of this test (e.g. condition and setting of springs and other suspension components and suspension geometry) shall be as specified by the manufacturer.

2.4.2. Height-levelling systems should be deactivated (held at static values) during the actual tilt to avoid inflation/deflation of suspension during the tilt. Cross-coupling from side to side may need to be deactivated. An exception can be made for levelling systems with very short response time of less than one second.

3. MEASURING ACCURACY

3.1. The tilt table angle shall be measured with an accuracy of better than 0.3°

4. NON POWER-DRIVEN VEHICLES

4.1. If the vehicle is a centre-axle trailer, the vehicle may be tested with a power-driven vehicle. Any power-driven vehicle, substitute or support which has the appropriate coupling system and height may be used, as this will not influence the results.

4.2. If the vehicle is a semi-trailer, the vehicle shall be tested with a tractor or a substitute. The tractor/substitute will influence the results and therefore a [reference tractor/substitute] shall be used.

5. VEHICLE LOADING CONDITION

The standard test condition is the maximum loaded condition; the laden vehicle. In this maximum loading condition, the tank vehicle shall be fully loaded, without exceeding the maximum authorized mass and maximum authorized axle loads.

If the normal load to be carried by the tank vehicle is classified as being of a dangerous type, it may be replaced by water or another non-dangerous test load. If the standard test conditions, (a) fully laden or (b) maximum mass, cannot be fulfilled with this test load then:

(a) a filling factor of the tank between 100 per cent and 70 per cent is acceptable. If at the minimum filling factor of 70 per cent the total mass and/or axle loads still exceed the maximum authorized mass and maximum authorized axle loads, a test load with a lower density shall be used. The distribution of mass of the tank (including the test load) among the axles shall be proportional to the maximum loaded condition.

Tanks provided with compartments shall be differentially loaded so that the centre of gravity height at each axle or axle group is as close as possible to the real centre of gravity height.

(b) a calculation shall be issued by the vehicle manufacturer 1/ to provide a new required maximum tilt table angle for the lighter test load.

6. SAFETY

Restraints shall be used to prevent final rollover but these shall be arranged so as not to interfere with the test.

1/ Manufacturer of the base vehicle or the final assembler of the tank vehicle.

7. TEST PROCEDURE

This procedure consists of a very gradual increase in the tilt table angle up to the required maximum angle or the rollover threshold. The vehicle shall be tested with all units in a straight line parallel to the tilt table axis such that no axle longitudinal centre line is off line by more than 25 mm.

All steerable axles of the vehicle shall be locked to prevent axle lateral movement and/or turning of the wheels in a steering direction. Also the vehicle shall be fixed in the longitudinal direction to prevent forward and rearward movement, provided that the method of fixing does not influence the test result.

The vehicle shall be tilted at very low rates of 0.25 °/s or less. The vehicle shall be gradually tilted three times each to the right and left of the vehicle longitudinal centre line. Due to the influences of stick-slip in the vehicle's suspension systems and coupling components, the vehicle shall be removed from the table between the tests and driven around to "randomize" and "equalize" the influences of stick-slip and hysteresis.

Annex 4

LATERAL STABILITY CALCULATION

1. GENERAL

The lateral stability of tank vehicles is calculated by simulation of a steady state circular test (constant radius, constant speed and consequently constant lateral acceleration). The calculation method take into account the main factors which influence the stability, such as the height of the centre of gravity, the track width and all factors which result in a lateral shift of the centre of gravity (axle roll stiffness, suspension roll stiffness, etc.). In case of semi-trailers the tractor will be simulated with a reference kingpin roll stiffness.

The specifications of the calculation method are:

1. axle roll centre is at ground level;
2. vehicle structure is assumed to be rigid;
3. vehicle is symmetrical about its centreline;
4. tyre and suspension deflections are linear;
5. lateral deflection of suspensions is zero.

2. DEFINITIONS

For the purposes of this calculation:

"Bogie" means an axle group with compensatory load distribution, in which zero load is attained on all wheels on a given side simultaneously.

3. SYMBOLS (see also Figure 1)

i	(-)	=	axle/bogie index ($i = 1 - n$, front to - axle/bogie; $i = T$, all axles/bogies; $i = M$, stiffest axle/bogie; and for semi-trailers only $i = K$, kingpin)
m_i	(m)	=	nominal suspension roll axis height
A_i	(kN)	=	axle/bogie load
C_{DGi}	(kNm/rad)	=	suspension roll stiffness at axle roll axis
C_{DGMi}	(kNm/rad)	=	equivalent suspension roll stiffness at ground level
C_{DRi}	(kNm/rad)	=	axle/bogie roll stiffness
C_{DRESi}	(kNm/rad)	=	resolved combined suspension roll stiffness at ground level

F_{RVi}	(kN/m)	=	vertical tyre rate for each axle/bogie (inclusive the double effect of twin tyres)
U_i	(kN)	=	unsprung weight
T_{Ni}	(m)	=	nominal track width
T_i	(m)	=	theoretical track width for axle/bogie with twin tyres
F_E	(-)	=	effective mass factor of stiffest axle/bogie
H_G	(m)	=	centre of gravity height of complete vehicle
H_N	(m)	=	centre of gravity height of sprung mass
MA	(m)	=	twin tyre width
q_c	g	=	corrected lateral acceleration at overturn
q_M	g	=	lateral acceleration at first wheel lift
q_T	g	=	maximum optimal lateral acceleration at overturn
g	(m/s ²)	=	acceleration due to gravity; $g = 9.81 \text{ m/s}^2$
θ_i	(rad)	=	vehicle pseudo-roll angle at wheel lift
β	(deg)	=	equivalent tilt table angle

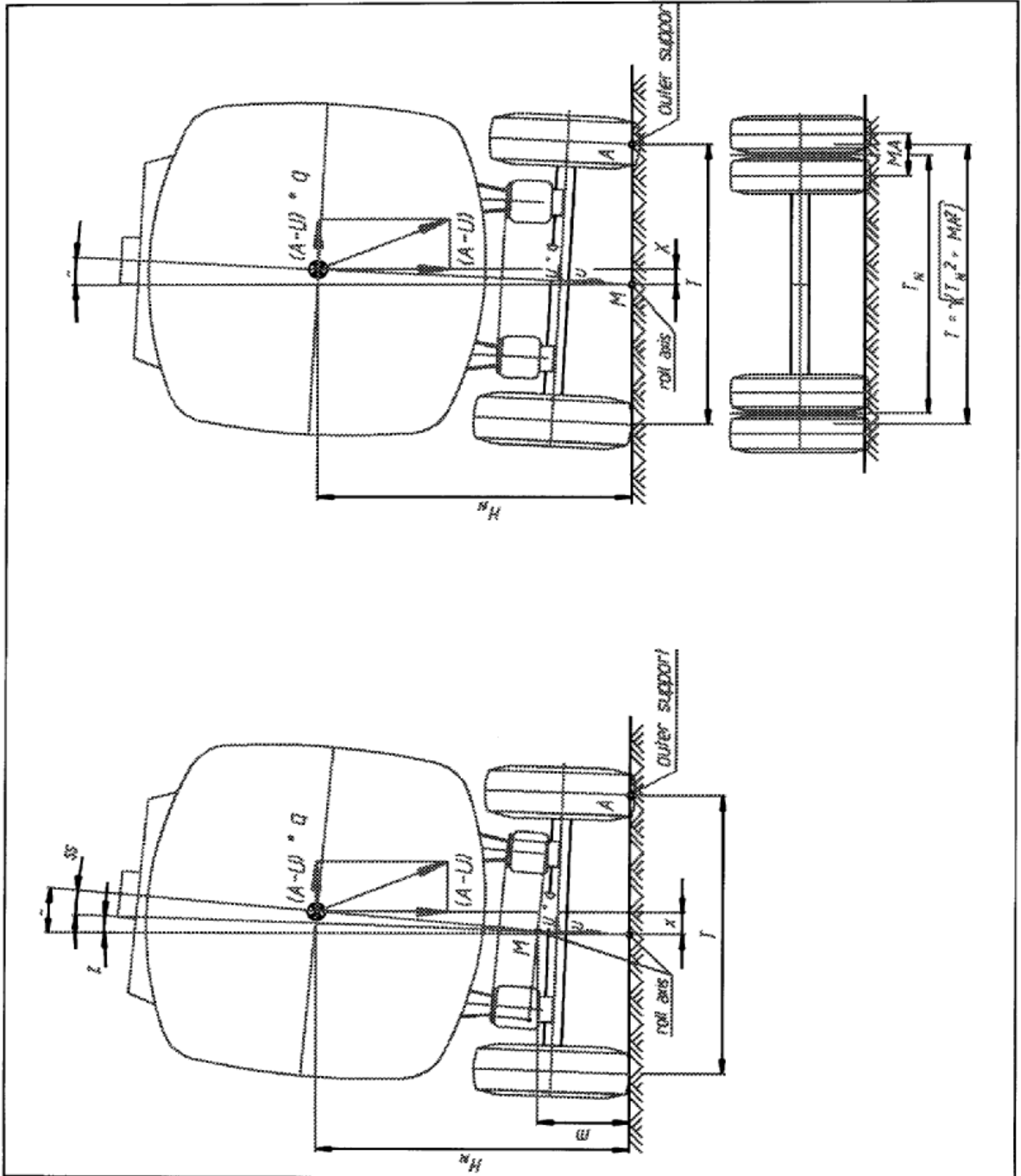

Figure 1: Cross section of a tank vehicle

4. GENERAL CONDITIONS

Height-levelling systems are not taken into account (held at static values).

5. TRAILERS

5.1. If the trailer is a full trailer or a central axle trailer the calculation does not have to include the coupling with the towing vehicle.

5.2. If the trailer is a semi-trailer, the tractor will be simulated with a reference kingpin roll stiffness, which represents the tractor suspension, tyres, chassis & fifth wheel flexibility at ground level.

6. VEHICLE LOADING CONDITION

The test condition is the maximum loaded condition; laden vehicle. In this maximum loading condition, the tank vehicle shall be fully loaded, without exceeding the maximum authorized mass and maximum authorized wheel loads.

7. CALCULATION METHOD

7.1. Calculation of the combined roll stiffness and the pseudo vehicle roll angle at wheel lift of each axle/bogie with the formulae:

7.1.1. axles/bogie with single tyres:

axle/bogie roll stiffness:

$$C_{DRi} = \frac{F_{Rvi} \times T_{Ni}^2}{2}$$

equivalent suspension roll stiffness ground level:

$$C_{DGMi} = C_{DGi} \times \left[\frac{H_N}{H_N - m} \right]^2$$

combined roll stiffness to simulate lateral CG shift:

$$C_{DRESi} = \frac{C_{DGMi} \times C_{DRi}}{C_{DGMi} + C_{DRi}}$$

pseudo vehicle roll angle at wheel lift:

$$\theta_i = \frac{A_i \times T_{Ni}}{2 \times C_{DRESi}}$$

7.1.2. axles/bogie with twin tyres:

theoretical track width for twin tyres:

$$T_i = \sqrt{T_{Ni}^2 + MA^2}$$

axle/bogie roll stiffness:

$$C_{DRi} = \frac{F_{Rvi} \times T_i^2}{2}$$

equivalent suspension roll stiffness ground level:

$$C_{DGMi} = C_{DGi} \times \left[\frac{H_N}{H_N - m} \right]^2$$

combined roll stiffness to simulate lateral CG shift:

$$C_{DRESi} = \frac{C_{DGMi} \times C_{DRi}}{C_{DGMi} + C_{DRi}}$$

vehicle pseudo-roll angle at wheel lift:

$$\Theta_i = \frac{A_i \times T_i}{2 \times C_{DRESi}}$$

7.2. In case of semi-trailers, calculation of the kingpin effects with the following formulae:

track width:

$$T_K = \frac{\sum_{i=1}^n T_i}{n}$$

roll stiffness: 1/

$$C_{DRESK} = A_K \times 4$$

7.3. After the resolved combined stiffness and pseudo roll angle for each axle/bogie are calculated the totals for the complete vehicle are determined:

total vehicle weight 2/ :

$$A_T = \sum_{i=1}^n A_i + A_K$$

1/ Factor 4 is expressed in m/rad.

2/ Use second part of the formula only for semi-trailers.

total unsprung weight:
$$U_T = \sum_{i=1}^n U_i$$

effective track width $\underline{2}$ /:
$$T_T = \frac{\sum_{i=1}^n (T_i \times A_i)}{A_T} + \frac{T_K \times A_K}{A_T}$$

total roll stiffness $\underline{2}$ /:
$$C_{DREST} = \sum_{i=1}^n C_{DRESi} + C_{DRESK}$$

7.4. Select the axle/bogie with the lowest value of θ , for this indicates that first wheel lift will occur. To distinguish this axle/bogie from the other axles/bogies, allocate the following:

- A_M = axle load of axle/bogie with lowest θ
 U_M = Unsprung weight of axle/bogie with lowest θ
 T_M = Track width of axle/bogie with lowest θ
 C_{DRESM} = roll stiffness axle of axle/bogie with lowest θ

7.5. Lateral stability calculation

7.5.1. The effective mass factor of the stiffest axle/bogie F_E :

$$F_E = \frac{C_{DRESM}}{C_{DREST}}$$

7.5.2. The lateral acceleration at first wheel lift q_M :

$$q_M = \frac{A_M \times T_M}{2 \times \left[(F_E \times A_T \times H_G) + \frac{((A_T - U_T) \times F_E \times H_N)^2}{C_{DRESM} - (A_T \times F_E \times H_N)} \right]}$$

7.5.3. The maximum optimal theoretical lateral acceleration at overturn q_T :

$$q_T = \frac{A_T \times T_T}{2 \times \left[(A_T \times H_G) + \frac{((A_T - U_T) \times H_N)^2}{C_{DREST} - (A_T \times H_N)} \right]}$$

7.5.4. Linear interpolation between the lateral acceleration at first wheel lift and the maximum theoretical lateral acceleration gives the correlated lateral acceleration at overturn q_c :

$$q_c = q_T - (q_T - q_M) \times \frac{A_M}{A_T}$$

Annex 4 - Appendix

CALCULATION REPORT

1. Trade name or mark of the vehicle:.....
2. Vehicle type:.....
3. Manufacturer:.....
4. Height of the centre of gravity of the sprung mass:.....
5. Unsprung weight of all axles:.....
6. Nominal suspension roll axis height of all axles:.....
7. Suspension roll stiffness of all axles:.....
8. Vertical tyre rate (inclusive double effect of twin tyres):.....
9. In case of twin tyres, the twin tyre width:.....
10. Calculation result, $q_c =$
11. Technical Service which carried out the calculation:.....
12. Date:
13. Signature:
